

CPC Pumps International Inc.

Part of the Atlas Copco
Gas and Process Division

CPC Pumps International Inc.

Partnering in engineered, process-critical pump applications.

Building on more than 50 years of industry experience and unique design and production capabilities, CPC Pumps International Inc. provides pump solutions for the hydrocarbon industry.

With our broad range of solutions and best-in-class hydraulic performance coverage, CPC Pumps provides our customers with tailor-made pump solutions for process-critical applications. Our focus on serving the market for fully compliant API 610 centrifugal pumps has made us a leading innovator in the hydrocarbon processing industry.

As an innovator, we always have our sights set on the present and the future. The world is quickly moving towards a circular economy and the goal of Net Zero Emissions by 2050. Many of the processes in which pumps are already used today will also be essential going forward, with CPC's technology helping to drive this transformation.



Engineering and Design

Your partner for engineered process-critical API 610 pumps

Designed with care, the features of our hydrocarbon pumps help increase the plant reliability and profitability of our customers.

Its long, extensive experience and established heritage has transformed CPC Pumps International into a highly capable, resourceful and responsive partner to customers in the hydrocarbon processing industry.

CPC is an industry leader that provides fully customized hydraulics through its reliance on the latest Computational Fluid Dynamics (CFD) and Finite Element Analysis (FEA) software. Our approach enables rapid design and manufacturing capabilities.

We also draw from a rich, experienced talent pool of dedicated professionals.



Manufacturing Capabilities

Our modern pumps production facility is located in Burlington (Ontario, Canada) - our global center of excellence for centrifugal hydrocarbon pumps.

Among other key production and testing capabilities, it features:

- State-of-the-art production machinery test stand including a 30,000 gallon (114 m³) tank motor drivers rated up to 4,500 HP (3,350kW).
- Variable Frequency Drives (VFD) and customized transformers allow testing at any speed and most common voltage requirements. Our test stand is equipped to handle complete unit testing (voltage up to 13.6kV).



Testing Capabilities

To ensure that CPC pumps meet our customer's specifications and expectations, each hydrocarbon pump unit must successfully pass the following quality tests:

- Hydrostatic pressure.
- Hydraulic performance.
- Vibration.
- Mechanical reliability.
- Air test of complete assembled unit prior to shipment.

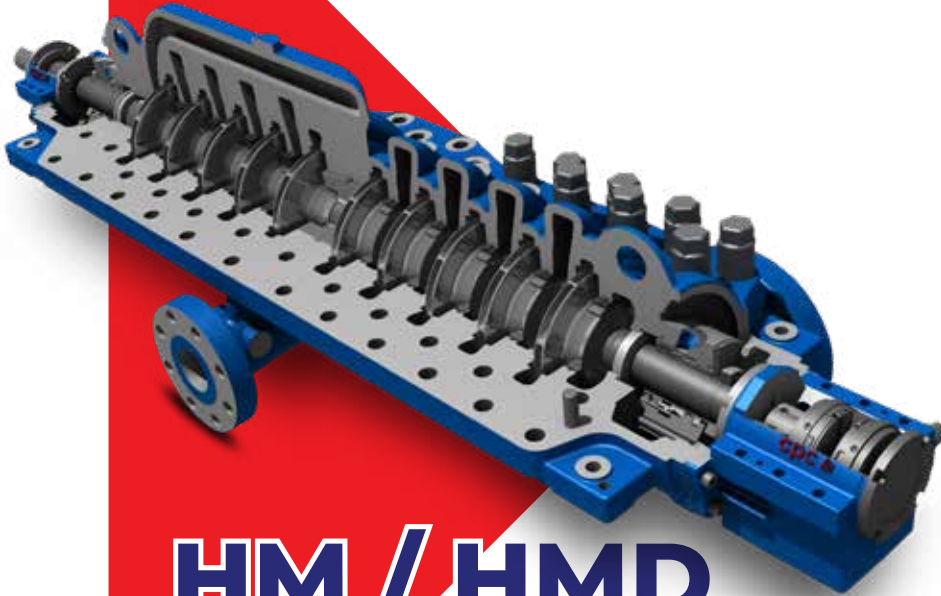

HM / HMD (BB3)

Multistage single or double-suction. First stage pumps fully compliant with API 610 requirements

Operating Parameters

- Flow rate in excess of 4,400 USGPM (1,000 m³/h).
- Differential heads up to 7,600 ft and 2,300 m.
- Temperatures up to 400 Deg. F (200 Deg. C).
- Standard Design Working Pressure of 2,250 PSIG (15,000 kpag).

Optional Features

- High pressure special casing design.
- Positive retention of impellers in both directions.
- Fan/Heat-sink bearing housing cooling arrangement for operation at elevated temperatures, to eliminate the need for cooling water.
- Magnetic bearing housing isolators.
- All bearing combination arrangements are available where suitable: Ball/Ball, Sleeve/Ball, Tilt Pad/Sleeve.

Standard Features

- Wide hydraulic coverage.
- Application tailored hydraulic selections.
- 600/900/1500# flange ratings.
- Available in all API 610 Table H.1 materials.
- Single-suction first stage (HM) or double-suction first stage (HMD).
- Hydraulically opposed impeller arrangement for thrust balancing.
- Axially split, precision milled parting flanges.
- Split case wear rings and center bushings for ease of maintenance.
- Integral balance line.
- Rigid design shaft for minimal deflection to meet and exceed API 610 requirements.
- Inpro/Seal bearing housing closures.
- Heavy Duty baseplate, drip rim or drip pan designs.

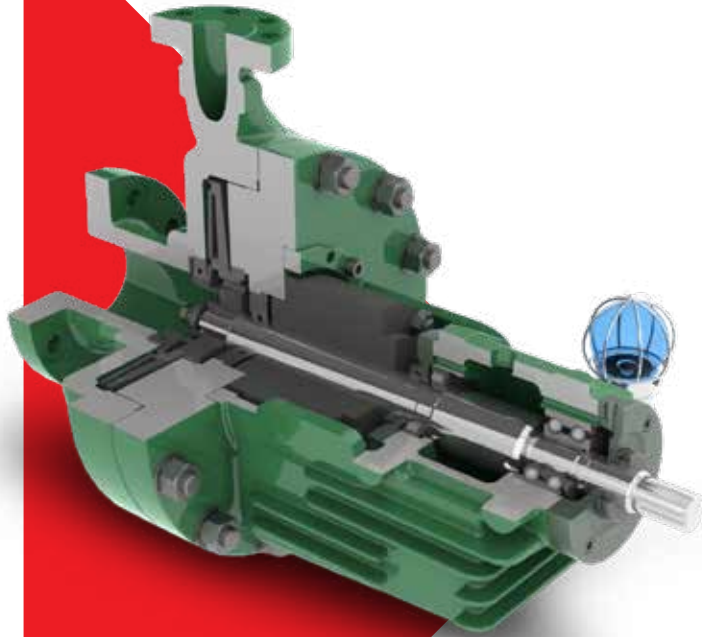

MODEL HR/ HOR (OH2)

Fully compliant with API 610 requirements

Operating Parameters

- Flow rate in excess of 15,000 USGPM (3,400 m³/h).
- Differential heads up to 1,300 ft and 395 m.
- Temperatures up to 800 Deg. F (425 Deg. C).
- Standard Design Working Pressure of 725 PSIG (5,000 kpag).
- Higher pressure designs available, in excess of 1,450 PSIG (10,000 kpag).

Optional Features

- Semi-open Coke Crusher design, with wear plate.
- High pressure special casing design.
- Oil Flinger/Oil Ring/Purge Mist/Pure Oil lubrication of bearings.
- Oversized shafts and bearing housing arrangements.
- Fan/Heat-sink bearing housing cooling arrangement for operation at elevated temperatures, to eliminate the need for cooling water.
- Magnetic bearing housing isolators.
- Pre-grouted baseplates or non-grouted baseplates.
- Non-standard API 610 material available.

Standard Features

- Widest hydraulic coverage in the industry.
- Application tailored hydraulic selections.
- 300# flange ratings, with end suction or top suction design casings.
- Available in all API 610 Table H.1 materials.
- Cast or fabricated impellers, for expanded hydraulic coverage.
- Close clearance metalized carbon throat bushing for optimal control of stuffing box environment.
- Rigid design shaft for minimal deflection to meet and exceed API 610 requirements.
- Cylindrical roller radial bearings for ample load carrying capability.
- Duplex angular contact 7300 series thrust bearings.
- Inpro/Seal bearing housing isolators.
- Heavy Duty baseplate, drip rim or drip pan designs.



MODEL VP-B (OH3)

Fully compliant to API 610 requirements.

Operating Parameters

- Flow rate in excess of 10,000 USGPM and 2,272 m³/h.
- Differential heads up to 1,300 ft and 395 m.
- Temperatures up to 800 Deg. F (425 Deg. C).
- Standard Design Working Pressure of 725 PSIG (5,000 kpag).
- Higher pressure designs available, in excess of 1,450 PSIG (10,000 kpag).

Optional Features

- Semi-open Coke Crusher design, with wear plate.
- High pressure special casing design.
- Oversized shafts and bearing housing arrangements.
- Magnetic bearing housing isolators.
- Mounting plate.
- Soleplate.
- Thrust Pod (TP) design, for extra heavy thrust loads, with oil bath lubrication.
- Non-standard API 610 material available.

Standard Features

- Widest Hydraulic coverage in the industry.
- Application tailored hydraulic selections.
- 300# flange ratings.
- Available in all API 610 Table H.1 materials.
- Cast or fabricated impellers, for expanded hydraulic coverage.
- Close clearance metalized carbon throat bushing, for optimal control of stuffing box environment.
- Rigid design shaft for minimal deflection meets and exceeds
- API 610 requirements.
- Cylindrical roller radial bearings for ample load carrying capability.
- Duplex angular contact 7300 series thrust bearings.
- Grease or pure mist lubrication.
- Inpro/Seal bearing housing closures.



MODEL VP-C (OH4)

Fully compliant with API 610 requirements

Operating Parameters

- Flow rate in excess of 10,000 USGPM and 2,272 m³/h.
- Differential heads up to 1,300 ft and 395 m.
- Temperatures up to 800 Deg. F (425 Deg. C).
- Standard Design Working Pressure of 725 PSIG (5,000 kpag).
- Higher pressure designs available, in excess of 3,750 PSIG (26,000 kpag).

Optional Features

- High pressure special casing design.
- Oversized shafts.
- Cartridge design Impeller bearing, for ease of maintenance.
- Air-Ex Stuffing Box spacer, for high temperature or Cryogenic applications.
- Mounting plate.
- Soleplate.

Standard Features

- Widest hydraulic coverage in the industry.
- Application tailored hydraulic selections.
- 300# flange ratings.
- Available in all API 610 Table H.1 materials.
- Cast or fabricated impellers.
- Close clearance metalized carbon impeller bearing, a combination radial bearing/throat bushing.
- Rigid design shaft for minimal deflection meets and exceed API 610 requirements.
- Product lubricated impeller bearing.
- Tri-Link patented rigid spacer coupling, allowing removal of seal cartridge without disturbing driver.

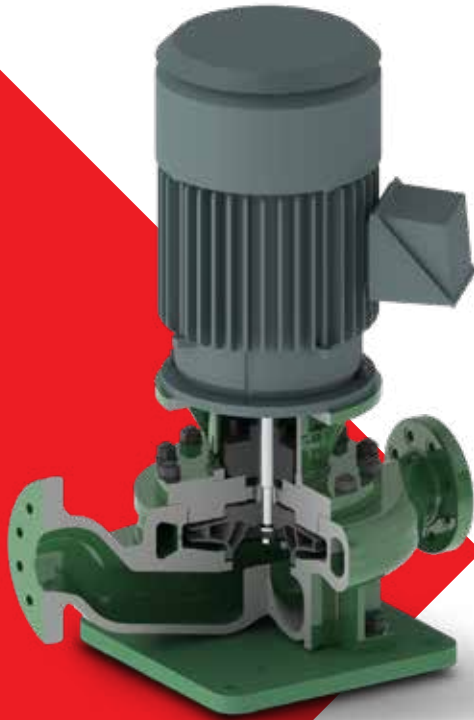

MODEL VP-M (OH5)

Fully compliant to API 610 requirements.

Operating Parameters

- Flow rate in excess of 8,000 USGPM (1,800 m³/h).
- Differential heads up to 1,200 ft (365 m).
- Temperatures up to 300 Deg. F (150 Deg. C).
- Standard Design Working Pressure of 725 PSIG (5,000 kpag).

Optional Features

- Mounting plate.
- Soleplate.

Standard Features

- Widest hydraulic coverage in the industry.
- Application tailored hydraulic selections.
- 300# flange ratings.
- Available in all API 610 Table H.1 materials.
- Cast or fabricated impellers.
- Close clearance metalized carbon impeller bearing, a combination radial bearing/throat bushing.

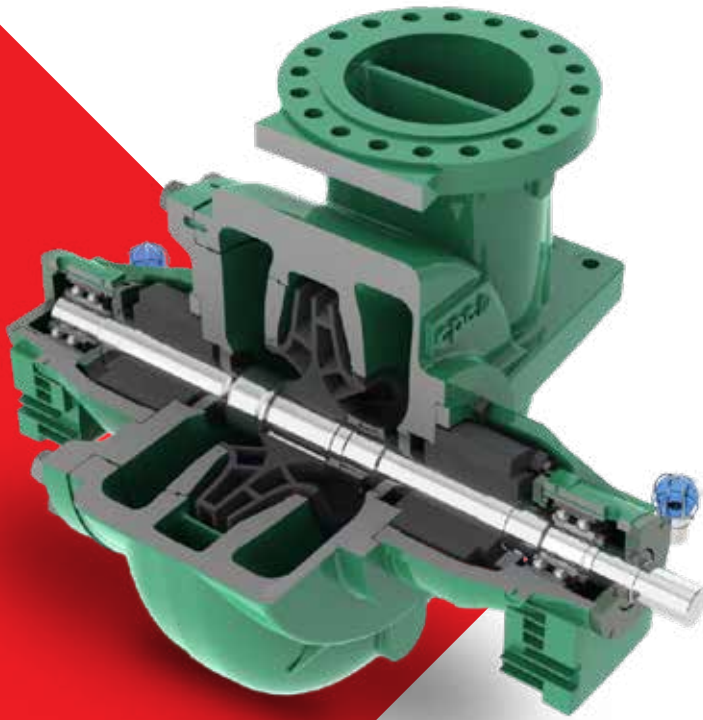

MODEL HDR (BB2)

Two-stage single or double-suction first-stage pumps. Fully compliant with API 610 requirements.

Operating Parameters

- Flow rate in excess of 15,000 USGPM and 3,400 m³/h.
- Differential heads up to 1,400 ft (425 m).
- Temperatures up to 800 Deg. F (425 Deg. C).
- Standard Design Working Pressure of 725 PSIG (5,000 kpag).
- Higher pressure designs available.

Optional Features

- High pressure special casing design.
- Oversized shafts and bearing housing arrangements.
- Fan/Heat-sink bearing housing cooling arrangement for operation at elevated temperatures, to eliminate the need for cooling water.
- Magnetic bearing housing isolators.
- All bearing combination arrangements are available where suitable: Ball/Ball, Sleeve/Ball, Tilt Pad/Sleeve.

Standard Features

- Widest hydraulic coverage in the industry.
- Application tailored hydraulic selections.
- 300# or 600# flange ratings, with top suction top discharge design casings.
- Available in all API 610 Table H.1 materials.
- Close clearance metalized carbon throat bushing, for optimal control of stuffing box environment.
- Rigid design shaft for minimal deflection to meet and exceed API 610 requirements.
- Inpro/Seal bearing housing closures.
- Heavy duty baseplate, drip rim or drip pan designs.

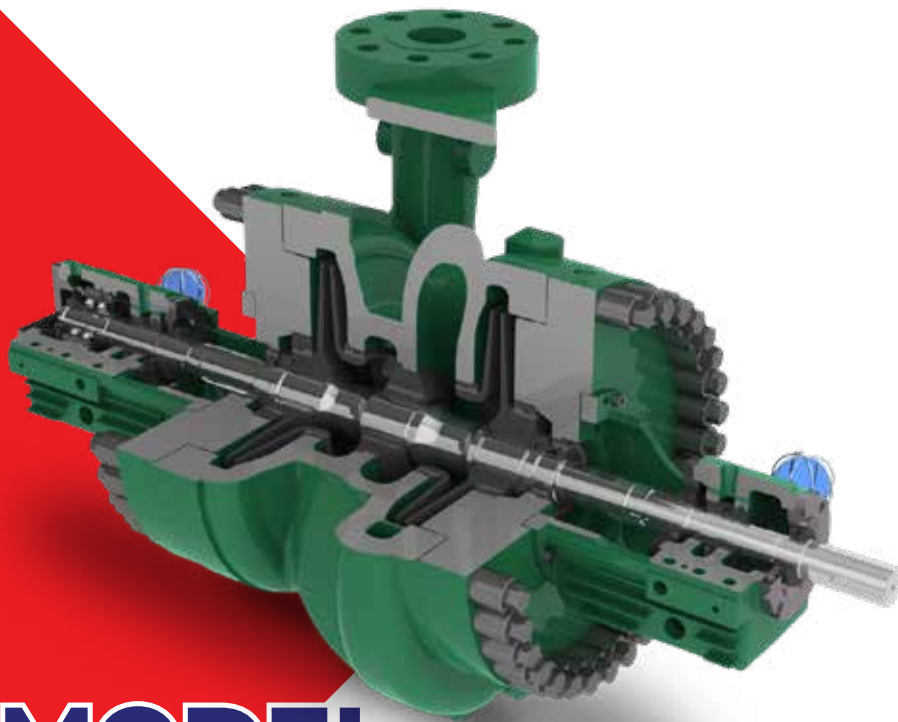

MODEL H2R (BB2)

Two-stage single or double-suction first-stage pumps. Fully compliant with API 610 requirements.

Operating Parameters

- Flow rate in excess of 8,100 USGPM (1,840 m³/h).
- Differential heads up to 2,800 ft (850 m).
- Temperatures up to 800 Deg. F (425 Deg. C).
- Standard Design Working Pressure of 725 PSIG (5,000 kpag).
- Higher pressure designs available.

Optional Features

- High pressure special casing designs.
- Fan/Heat-sink bearing housing cooling arrangement for operation at elevated temperatures, to eliminate the need for cooling water.
- Magnetic bearing housing isolators.
- All bearing combination arrangements are available where suitable: Ball/Ball, Sleeve/Ball, Tilt Pad/Sleeve.

Standard Features

- Widest hydraulic coverage in the industry.
- Application tailored hydraulic selections.
- 600/900/1500# flange ratings.
- Controlled compression fully confined gasket fit, case to cover.
- Available in all API 610 Table H.1 materials.
- Close clearance metalized carbon throat bushing for optimal control of stuffing box environment.
- Rigid design shaft for minimal deflection to meet and exceed API 610 requirements.
- Inpro/Seal bearing housing closures.
- Rigid cast Carbon steel bearing housings, with fins for improved heat dissipation.
- Heavy duty baseplate, drip rim or drip pan designs.

Vast production process experience, best-in-class lead times

Due to CPC's extensive experience in managing the complete production process for complex and highly customized hydrocarbon pumps, our customers benefit from enhanced on-time delivery performance and best-in-class lead times.

Combined with highly qualified local third-party capabilities, CPC's production system is constantly expanding to handle high volumes and complex customer requirements.





Part of the Atlas Copco Gas and Process Division

CPC Pumps International Inc. is part of Atlas Copco Gas and Process. It is operated as a standalone company within Atlas Copco Gas and Process, and serves as competence center of excellence for centrifugal pumps in Atlas Copco.

CPC Pumps International Inc.

Part of the Atlas Copco Gas and Process Division
5200 Mainway, Burlington, ON, Canada L7L 5Z1
Phone: +1 (289) 288-0264 x 278, www.cpcpumps.com

© CPC Pumps International Inc. August 2022.